

PENTAX 17

Operating Manual

The serial number is located on the bottom of the camera.

Chapter 1: Introduction

Read this chapter before use.

This chapter gives you an overview of the PENTAX 17.

Chapter 2: Getting Started

Read this chapter before using the PENTAX 17 for the first time.

This chapter explains necessary preparations before shooting.

Chapter 3 and later

Read these chapters when you want to learn more about the different camera functions.

These chapters provide information on shooting and settings.



Model: R08010

Regarding User Registration

Thank you for purchasing a RICOH IMAGING product.

In order to provide you with the best customer support and service experience for the product you have purchased, we ask you to complete the user registration.

Visit the following website to complete the user registration.

<https://www.ricoh-imaging.com/registration/>

Introduction

This Operating Manual provides information on how to use the shooting functions of this camera and related precautions.

Thoroughly read this Operating Manual to make the best use of the functions available with this camera. Be sure to keep this Operating Manual for future reference.

<https://www.ricoh-imaging.co.jp/english/index.html>

RICOH IMAGING COMPANY, LTD.

Safety precautions	Read all safety precautions thoroughly to ensure safe use.
Copyright	Photos taken with this camera that are for anything other than personal enjoyment cannot be used without permission according to the rights as specified in the Copyright Act. Please take care, as there are cases where limitations are placed on taking photos even for personal enjoyment during demonstrations, performances or of items on display. Photos taken with the purpose of obtaining copyrights also cannot be used outside the scope of use of the copyright as laid out in the Copyright Act, and care should be taken here also.
Exemption from liability	RICOH IMAGING COMPANY assumes no liability for failure to take photos as a result of product malfunction.

This publication may not be reproduced in whole or in part without RICOH IMAGING COMPANY's express written permission.

© RICOH IMAGING COMPANY, LTD. 2024

RICOH IMAGING COMPANY reserves the right to change the contents of this manual at any time without prior notice.

There is the possibility that the illustrations in this manual are different from the actual ones.

Safety Precautions

We have paid close attention to the safety of this camera. When using this camera, we request your special attention regarding items marked with the following symbols.



Warning

This symbol indicates that ignoring this item could cause serious personal injuries.



Caution

This symbol indicates that ignoring this item could cause minor or medium personal injuries, or loss of property.

About the Camera



Warning

- Do not disassemble or modify the camera. High voltage areas are present inside the camera, with the risk of electric shock.
- If the camera interior is exposed due to dropping or otherwise damaging the camera, never touch the exposed portion. There is a risk of electric shock.
- Do not aim the camera at the sun or other strong light sources when taking photos or leave the camera sitting in direct sunlight with a lens cap off. Doing so may cause the camera to malfunction or cause a fire.
- Do not look through the viewfinder while pointing the lens at the sun. Doing so may lead to a loss of eyesight or cause vision to be impaired.
- If any irregularities occur during use, such as smoke or a strange odor, stop use immediately, remove the battery, and contact your nearest service center. Continued use can cause a fire or electric shock.



Caution

- Do not fire the flash while your hand is covering the emitter. Doing so may result in burns.
- Do not fire the flash while clothing, etc. is covering the emitter. Doing so may result in discoloration.
- Some portions of the camera heat up during use. There is a risk of low temperature burns when holding such portions for long periods.

About the Battery

Caution

- Only use the specified battery with this camera. Use of other batteries may cause an explosion or fire.
- Do not short the battery or dispose of the battery in fire. Also, do not disassemble or charge the battery. Doing so may result in explosion or fire.
- Remove the battery from the camera immediately if it becomes hot or begins to smoke. Be careful not to burn yourself during removal.

Handling the Camera and Accessories

Warning

- Do not place the camera and its accessories within the reach of small children.
 - Take care to keep the battery and battery cover screw out of reach of children to prevent accidental swallowing. Seek medical attention immediately if the battery or screw is accidentally swallowed.
 - Wrapping the strap around a neck may cause suffocation.
 - If the product falls or is operated accidentally, it may cause serious personal injuries.
- Depending on your individual factors or physical condition, the use of the camera may cause itching, rashes or blisters. In case of any abnormality, stop using the camera and get medical attention immediately.

Contents

Introduction	1
Safety Precautions	2
1 Introduction	5
Checking the Contents of the Package	5
Names and Functions of the Working Parts	6
Indicator Lamps	10
Viewfinder Display	11
2 Getting Started	12
Attaching the Strap	12
Inserting a Battery	13
Turning the Camera On	14
Preparing the Film	14
Compatible Film Types	14
Setting the Film Sensitivity	15
Inserting the Film	16
Rewinding the Film	20
Holding the Camera	21
3 Shooting	22
Shooting in the Full Auto Mode	22
Setting the Shooting Mode	23
Using the Flash for Shooting	24
Bulb Shooting	26
Setting the Shooting Range	27
Compensating the Exposure	29
Using a Filter	30
4 Appendix	31
Troubleshooting	31
Main Specifications	33
Handling Precautions	36
Warranty Policy	38
Regulatory Compliance Statements	41
Index	45

Checking the Contents of the Package

Before using your camera, confirm that the package contains the items listed below.

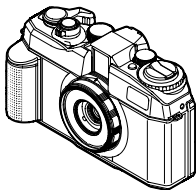

Camera



**Lens cap
(O-LC40.5)**

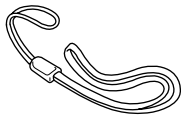

**Strap
(O-ST191)**

Start Guide

Names and Functions of the Working Parts

1

Introduction

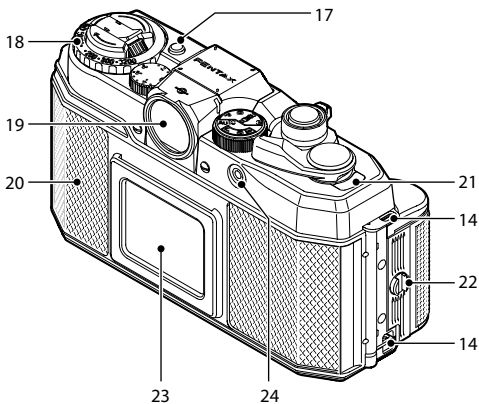
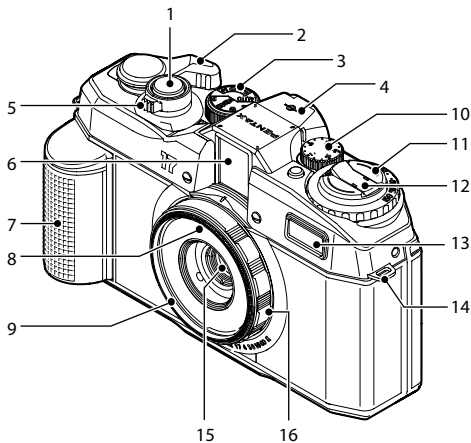

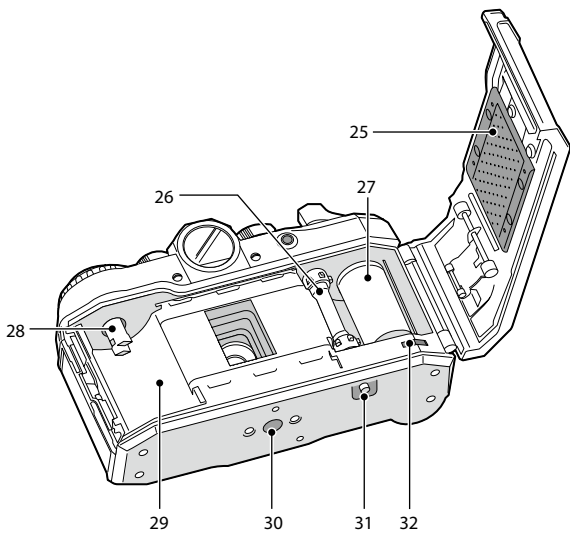

- 1 Shutter release button**
Press to shoot. (p.22)
- 2 Film advance lever**
Advances the film to the next frame. (p.17)
- 3 Mode dial**
Changes the shooting mode. (p.23)
- 4 Film surface position indicator**
Shows the location of the film surface (imaging focal position).
- 5 Main switch**
Turns the power on or off. (p.14)
- 6 Viewfinder window**
- 7 Grip / Battery cover**
Remove when inserting a battery. (p.13)
- 8 Metering unit**
Measures subject brightness.
- 9 Filter mounting thread (40.5mm)**
(p.30)
- 10 Exposure compensation dial**
Sets the exposure compensation value. (p.29)
- 11 Rewind knob**
Lift to open the rear cover when loading the film or removing the rewound film. (p.20)
- 12 Rewind crank**
Turn to rewind the exposed film into the cartridge (container that stores the film). (p.20)
- 13 Flash emitter**
(p.24)
- 14 Strap eyelets**
Used when attaching the strap. (p.12)
- 15 Lens**
- 16 Zone focusing ring**
Sets the zone you want in focus. (p.27)
- 17 ISO sensitivity dial lock release button**
Press to allow the ISO sensitivity dial to be turned. (p.15)
- 18 ISO sensitivity dial**
Sets the film ISO sensitivity. (p.15)
- 19 Viewfinder**
Used to check the subject composition and angle of view. (p.11)
- 20 Rear cover**
Open to load or remove the film. Keep closed at all other times. (p.16)
- 21 Film counter**
Shows the number of shots. (p.17)
- 22 Grip locking screw**
(p.13)
- 23 Note holder**
Holds a piece of film box or a note. (p.19)
- 24 Cable switch terminal**
Used when connecting the optional cable switch CS-205.
- 25 Film pressure plate**
Keeps the film flat.

- 26 Sprockets**
Align the film perforations (holes on both sides) when loading the film.
- 27 Winding spool**
Winds the exposed film.
- 28 Rewind shaft**
- 29 Cartridge chamber**
Load the film cartridge. (p.16)
- 30 Tripod socket**
Used when attaching the tripod.
- 31 Rewind button**
Press to rewind the exposed film into the cartridge. (p.20)
- 32 Film end indicator**
When loading the film, align the end with this indicator. (p.16)

Indicator Lamps

The two colored lamps next to the viewfinder indicate the camera status and warnings.

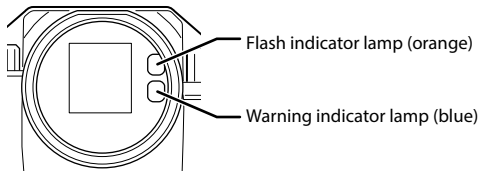

Warnings at camera startup

Orange	Blue	Status
Blinking quickly* ¹	Blinking quickly* ¹	Dead battery warning (shooting impossible)
—	Blinking quickly	Lens cap warning (low light)

Warnings when the shutter release button is pressed halfway

Orange	Blue	Status
Blinking quickly* ¹	Blinking quickly* ¹	Dead battery warning or film not-completely-advanced warning (shooting impossible)
—	Blinking quickly	Exposure warning* ²
—	Blinking slowly	Shooting range close-up (tabletop photo, macro) warning

Information during the shooting modes in which the flash fires

Orange	Blue	Status
Blinking slowly	—	Flash charging
Lit	—	Flash charging complete

*1 The orange and blue indicator lamps blink alternately.

*2 No warning is indicated for bulb exposure or when flash charging is complete.

Viewfinder Display

1 Visual field frame

Make sure the subject fits inside this frame when composing a shot. (p.22)

2 Close-up visual field compensation frame

When shooting close-ups (tabletop photo, macro), compose the shot so it fits inside this frame.

3 Zone focusing mark

You can check the zone focusing ring setting. (p.27)

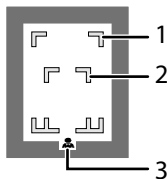

Attaching the Strap

2

Getting Started

- 1 Pass the narrow end of the provided strap through the strap eyelet of the camera.

Attach the strap to one of the three strap eyelets.

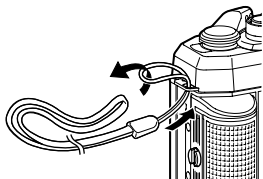

- 2 Pass the end of the strap through the loop and pull it tight.



Memo

- When using a commercially available neck strap, attach it as shown below.

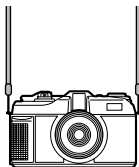

Suspended horizontally



Suspended vertically

Inserting a Battery

Make sure you have one CR2 3V lithium battery ready.

- 1** Use a coin, etc., to loosen the grip locking screw on the side of the camera, then remove the grip.

Take care not to lose the grip locking screw.

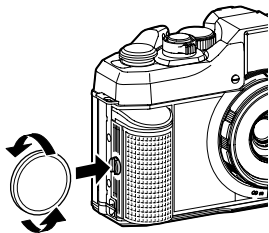

- 2** Check the battery orientation and insert it in the battery chamber.

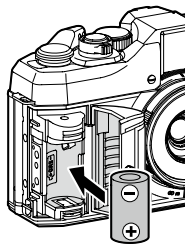

- 3** Attach the grip in the original position and tighten the grip locking screw.



Caution

- Rechargeable batteries cannot be used.



Memo

- Follow the same procedure to remove the battery.
- With a new battery, you can perform shooting with approx. 10 film cartridges (when using 36-shot film under the condition of 50% flash use).
- Make sure to dispose of used batteries according to local ordinances.

Turning the Camera On

1 Turn the main switch to the right.
The camera is turned on.

2 To turn the camera off, turn the main switch to the left.
The camera is turned off.

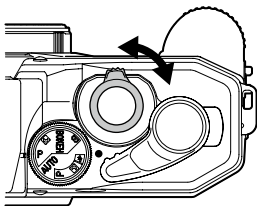

Memo

- The camera is automatically turned off if it is not operated for more than a minute after being turned on (Auto Power Off). To wake the camera from "Auto Power Off", press the shutter release button halfway.

Preparing the Film

Compatible Film Types

The following types of film can be used with the camera.

- 35mm film
- Film with the ISO sensitivity of 50, 100, 125, 160, 200, 400, 800, 1600, or 3200
- Film for up to 36 shots



Half-frame

- The camera uses the half-frame shooting format (24 × 17 mm).
- You can perform shooting double the number of shots shown on the film.
- When holding the camera horizontally, you can shoot portrait style compositions.
- When having your exposed film developed at a camera shop, etc., make sure to let them know it is half-frame.



Caution

- Infrared film cannot be used on the camera.

Setting the Film Sensitivity

Set the film sensitivity to match your film.
Make sure to set this when loading new film.

- 1 Check the film sensitivity on the film box, etc.
- 2 Set the ISO sensitivity dial to the appropriate setting while pressing the ISO sensitivity dial lock release button.

The following settings are available: 50, 100, 125*, 160*, 200, 400*, 800, 1600*, and 3200.

* Indicated as “*” on the dial.

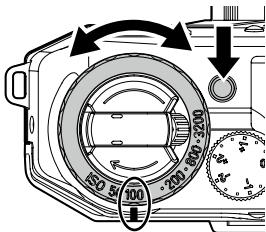

2

Getting Started



Caution -----

- The sensitivity setting is disabled in the shooting mode **B**.

Inserting the Film

Load the film in a location that is out of direct sunlight.

- 1** Set the mode dial to **P** and make sure the lens cap is attached on the camera.



- 2** Open the rewind crank and then lift the rewind knob gently until it stops.

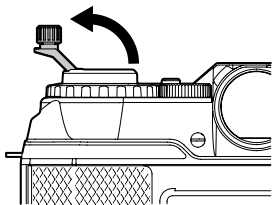

- 3** While holding the rewind knob, lift it straight up until the rear cover is open.

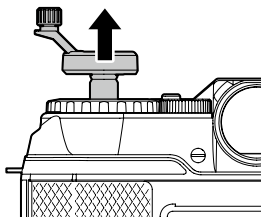

4 Load the film cartridge into the cartridge chamber with the cartridge shaft protrusion on the camera bottom side.

5 Pull the film leader (narrow section) out slightly and align it with the orange film end indicator.

Pull the film out little by little so that there is no slack, and align it with the indicator.

The film does not advance properly if it is not aligned with the film end indicator.

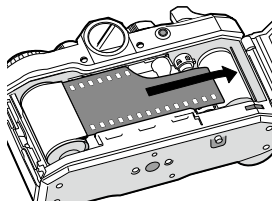

6 Close the rear cover.

Take care to keep the film flat while closing the cover.

7 Return the rewind knob and rewind crank to their original positions.

8 Turn the camera on.

9 Push the film advance lever to the right to advance the film.

The rewind knob rotates, the film is advanced, and the shutter is set.

If the film is advanced one frame, the film advance lever automatically returns to the original position.

The same operation is used to advance the film during shooting.

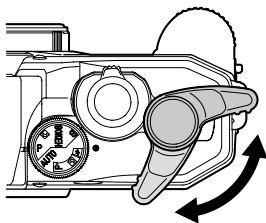

10 Press the shutter release button.

11 Repeat Steps 9 and 10 until the film counter reaches "0".

Check that the rewind knob rotates in accordance with film advance.

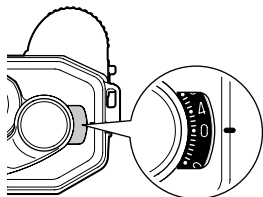

**Caution**

- When opening the rear cover, make sure to hold the rewind knob and pull it upward. Pulling the rewind crank can bend the rewind shaft.
- Take care not to pinch your fingers when closing the rear cover.
- Loading film with the lens cap off can result in exposure of unnecessary frames.
- Loading film with the mode dial set to anything other than **P** can fire the flash or start a long exposure unintentionally.
- The film is not loaded correctly if the rewind knob does not rotate when advancing the film.
- The film advance lever does not move when the film is already advanced or when the entire roll of film has been exposed. Do not forcefully turn it.
- Do not forcefully advance the film beyond the designated frames (number of shots specified for the film \times 2). (Example: For 24-shot film, do not advance it more than 48 frames.) Doing so can tear the film or cause it to break partway through the roll.
- The film counter goes to "72". The number does not change even if you advance the film beyond this point.

**Film Advance Lever Ready Position**

- If you move the film advance lever slightly, it stops in a position that makes it easier to advance the film (①). Turning it to the right thereafter advances the film.
- When moving from place to place, make sure to push the film advance lever all the way to the left so that it does not become caught on something and move on its own.

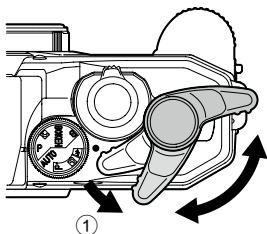

Using the Note Holder

You can use the note holder to hold a piece of the film box or a note.

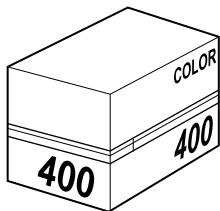
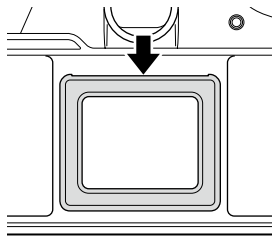

Rewinding the Film

Once the entire roll of film has been exposed, rewind it so that it is stored in the cartridge.

- 1 Press the rewind button.**
The film ready to be rewound.

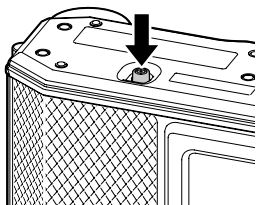

- 2 Open the rewind crank and turn it clockwise.**
The film is rewound.

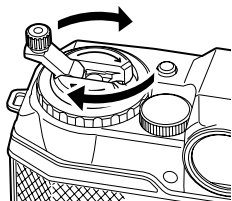

- 3 Once you feel little resistance, turn the rewind crank another three times.**
The film is stored in the cartridge.

- 4 Lift the rewind knob, open the rear cover, and remove the film cartridge.**

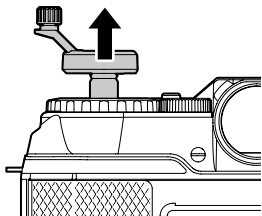

- 5 Close the rear cover, then return the rewind knob and rewind crank to their original positions.**

**Caution**-----

- Do not open the rear cover until rewinding is complete. Opening it part-way exposes the film and ruins any shots.
- Remove the film cartridge in a location that is out of direct sunlight.

**Memo**-----

- Even if you do not shoot to the end of the film, you can rewind it by pressing the rewind button.

Holding the Camera

When holding the camera horizontally, you can shoot portrait style compositions, and when holding it vertically, you can shoot landscape style compositions.

When shooting, hold the camera firmly in both hands and gently press the shutter release button with the ball of your finger. Take care not to shake the camera when shooting.

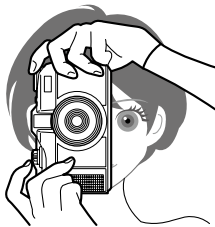
**Memo**-----

- To use the flash when holding the camera vertically, make sure the flash is on the top.
- Keeping your arms tight to your sides while shooting can prevent the camera from shaking.

Shooting in the Full Auto Mode

First, try some easy shooting in the full auto mode.



- 1 Turn the camera on.
- 2 Turn the mode dial to set the shooting mode to **AUTO**.

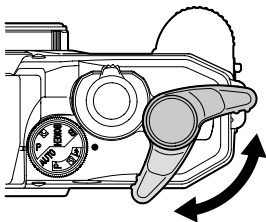

- 3 Hold the camera and look through the viewfinder.
- 4 Make sure the subject is inside the visual field frame and press the shutter release button halfway.
- 5 Press the shutter release button fully.
The camera takes a shot.
The focus is fixed regardless of the zone focusing setting.
The camera automatically fires the flash if necessary.

- 6 Advance the film.
The film counter advances.



- Caution** -----
- The shooting mode **AUTO** does not support the zones  and  of the shooting range. Perform shooting at least 1 m away from the subject.



Operating the Shutter Release Button

- The shutter release button has two stages.

Halfway press	Press the shutter release button slightly. Metering is performed. The indicator lamps light up or blink if necessary.
Full press	From the halfway press position, press the shutter release button fully to activate the shutter.

Setting the Shooting Mode

Turn the mode dial to set a shooting mode.

Shooting Mode	Exposure Control	Flash	Focus
AUTO Full auto	Pan focus program	Auto flash	Fixed
P Standard	Program	Flash off	Set with the zone focusing ring
Slow-speed shutter	Slow-speed program		
BOKEH Maximum aperture priority	Maximum aperture priority program		
B Bulb	Maximum aperture bulb	Flash on	
P Daylight sync	Program		
Slow-speed sync	Slow-speed program		





Memo



- Use of a tripod and the optional cable switch (CS-205) is recommended in , **B**, and .
- The shutter speed is delayed up to 4 seconds in and .
- The aperture is fixed to F3.5 in **B**.

Using the Flash for Shooting

You can force the flash to fire for shooting.

1 Turn the camera on.

2 Set the shooting mode to P  or  .

P  Daylight sync	The flash is fired in situations when the subject is backlit or in shadow. The shutter speed is up to 1/30 seconds.
  Slow-speed sync	When taking photos of a person against a dark background, the flash is fired at the person and the background is exposed using the slow-speed shutter. The shutter speed is up to 4 seconds.

The flash indicator lamp (orange) blinks and the flash is charged.

When charging is complete, the flash indicator lamp changes from blinking to lit.

3 Set the shooting range.

Refer to "Setting the Shooting Range" (p.27).

4 Look through the viewfinder, make sure the subject is inside the visual field frame, and press the shutter release button halfway.

5 Check that the flash indicator lamp (orange) is lit.

6 Press the shutter release button fully.

7 Advance the film.

**Memo** -----

- The range that the flash light reaches depends on the ISO sensitivity of the film used. As a rough guide, the flash light can reach up to the “close distance” zone when using film of ISO 100 and up to the “medium distance” zone when using film of ISO 400 or higher.
- In some cases, the flash may make the subject’s eyes appear red (red-eye effect).
- Because the shutter speed is delayed up to 4 seconds in , P is recommended for hand-held shooting without using a tripod.

**Caution** -----

- Note the following when using the flash for shooting with the zone of the shooting range set to or .
- The brightness may become uneven in the photo taken. In particular, when an accessory such as a filter and hood is attached to the lens, the brightness may be significantly uneven. Remove the filter, hood, etc. before performing shooting.
- Using film of a high ISO sensitivity results in overexposure. Use of the film of ISO 100 is recommended.

Bulb Shooting

While the shutter release button is pressed, an exposure is made.

1 Turn the camera on.

2 Set the shooting mode to **B**.

3 Set the shooting range.
Refer to "Setting the Shooting Range" (p.27).

4 Look through the viewfinder, check the subject, and press the shutter release button halfway.

5 Press and hold the shutter release button fully.
The exposure is continued while the shutter release button is pressed.

6 Release your finger from the shutter release button.
The exposure stops.

7 Advance the film.

 **Caution** -----

- The following settings are disabled during bulb shooting.
 - ISO sensitivity
 - Exposure compensation

 **Memo** -----

- The aperture is fixed to F3.5 during bulb shooting.

Setting the Shooting Range

1 Turn the zone focusing ring to the desired setting.

Select a zone depending on the distance to the subject.

The focusing range of each zone is as follows.

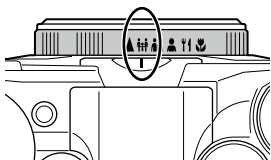

Zone	Focusing range in m (ft)
Far distance	5.1 m to ∞ (17 ft to ∞)
Medium distance	2.1 to 5.3 m (6.9 to 17 ft)
Close distance	1.4 to 2.2 m (4.6 to 7.2 ft)
Extremely close distance	1.0 to 1.4 m (3.3 to 4.6 ft)
Close-up (tabletop photo)	0.47 to 0.54 m (1.6 to 1.8 ft)
Close-up (macro)	0.24 to 0.26 m (0.79 to 0.85 ft)

The distance (representing value) of the selected zone can be checked on the front of the camera.

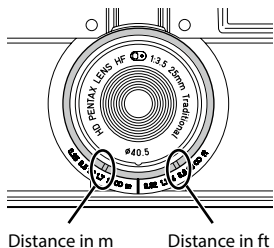

Memo

- You can see the zone focusing setting if you look through the viewfinder.

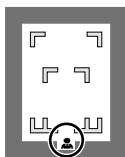
**Caution**

- The shooting range setting is disabled in the shooting mode **AUTO**.
- The range in focus is narrower in $\uparrow\uparrow$ and \uparrow , so the warning indicator lamp (blue) blinks slowly while the shutter release button is pressed halfway, indicating a close-up warning. Shooting is possible even when the lamp is blinking.

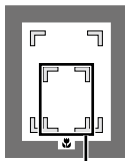

Macro shooting range

- You can measure a distance of approx. 0.25 m with the provided strap.

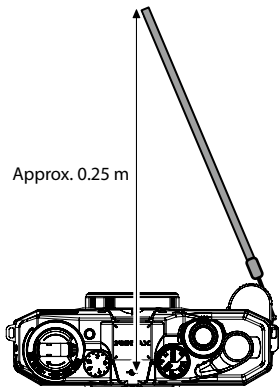

Compensating the Exposure

Exposure compensation prevents underexposure or overexposure when shooting white or black subjects. Use it when the exposure is insufficient, such as for backlit subjects. It can also be used to intentionally overexpose shots (for bright photos) or underexpose shots (for dark photos).

1 Turn the exposure compensation dial to the desired setting.

Compensation is available in a range of ± 2.0 EV in $1/3$ EV steps.

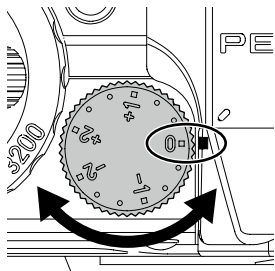

3

Shooting



Caution -----

- Exposure compensation is disabled in the shooting mode **B**.

Using a Filter

The camera is compatible with commercially available 40.5mm filters, which can be attached to the lens filter mounting thread.



Caution -----

- Using a colored filter or filter with density can make it impossible to obtain the correct exposure. Make sure to take some test shots in advance and use exposure compensation.
- If an exposure multiplying factor, etc., is required for a colored filter used with black and white film, compensation may not be possible in combination with the metering sensor. Make sure to take some test shots in advance.
- Using multiple filters may cause vignetting in the metering range, making it impossible to obtain the correct exposure. Make sure to use only one filter with a thin edge.

Troubleshooting

Problem	Cause	Remedy	Page
The camera does not turn on.	The battery is not inserted.	Insert the battery in the correct orientation.	p.13
	The battery is not in the correct orientation.		
	The battery is exhausted.	Replace the battery.	
	The battery is incompatible.	Make sure to use a CR2 3V lithium battery.	
The camera turns off during use.	The "Auto Power Off" function has been activated because the camera was not operated for a certain period of time.	Press the shutter release button halfway.	p.14
	The battery is exhausted.	Replace the battery.	p.13
Shooting is not possible.	The film has not been advanced.	Advance the film.	p.17
	The battery is exhausted.	Replace the battery.	p.13
	The camera is off.	Turn the camera on.	p.14
Autofocus does not work.	The lens is dirty.	Clean the lens with soft, dry cloth.	—
	The shooting range setting is incorrect.	Use the zone focusing ring to select the zone you want in focus.	p.27
	The subject is too close.	Use the macro mode for shooting or move away from the subject.	p.27

Problem	Cause	Remedy	Page
The flash does not discharge.	A shooting mode preventing flash operation is selected.	Check the shooting mode.	p.24
	The flash is charging.	Check that flash charging is complete.	

Main Specifications

Model Description

Type	Half-frame behind-the-lens shutter film camera
Frame Size	24 × 17 mm
Compatible Film	35mm film ISO 50, ISO 100, ISO 125, ISO 160, ISO 200, ISO 400, ISO 800, ISO 1600, ISO 3200
Sensitivity Setting	Manual settings to match the film
Film Loading	Easy loading
Film Advance	Manual advancing using advance lever (with 130-degree stroke and 35-degree stand-off angle)
Rewind	Manual rewinding using rewind crank, mid-roll rewinding possible

Lens

Lens	HD PENTAX lens
Focal Length	25mm (equivalent to 37mm in 35mm format)
Maximum Aperture	F3.5
Lens Configuration	3 elements in 3 groups
Angle of View	61° (diagonal)
Maximum Magnification	Approx. 0.13× (at 0.25 m)
Filter Diameter	Ø40.5 mm

Viewfinder

Type	Albada bright-frame viewfinder
Viewfinder Indication	Composition frame, Close-distance composition frame Zone focusing setting confirmation possible through the viewfinder
Viewfinder Outer Right	Blue lamp display: Warning display Orange lamp display: Flash display

Focusing

Type	Zone-focusing (manual operation)
Switchover Distance	6 zones (0.25 m, 0.5 m, 1.2 m, 1.7 m, 3 m, ∞ (0.82 ft, 1.7 ft, 4 ft, 5.6 ft, 10 ft, ∞))

Exposure Control

Metering Type	Partial metering
Metering Range	EV 2.5 to 16.5 (ISO100)
Exposure Compensation	±2 EV (1/3 EV steps)
Shooting Mode (Exposure)	Full auto (Pan focus program AE, Auto flash), Standard (Program AE, Flash off), Slow-speed shutter (Slow-speed program AE, Flash off), Maximum aperture priority (Maximum aperture priority program AE, Flash off), Bulb (Maximum aperture bulb, Flash off), Daylight sync (Program AE, Flash on), Slow-speed sync (Slow-speed program AE, Flash on)

Shutter

Type	Program AE electronic shutter
Shutter Speed	1/350 to 4 seconds, Bulb

Flash

Built-in Flash	Guide number: Approx. 6 (ISO 100, m) Covers the angle of view of a 25mm lens
Emission Type	Shooting mode interlocking system
Flash Charging Time	Approx. 9 seconds
Charging Status	Indicated with the orange lamp on the right side of the viewfinder Charging in progress: Blinking Charging completed: Lit

Power Source

Battery Type	One 3V lithium battery (CR2) Not compatible with rechargeable CR2 type batteries
Battery Life	Approx. 10 cartridges (when using 36-shot film under the condition of 50% flash use with a new battery set in the camera) * According to the result of RICOH IMAGING in-house testing

External Terminal

Cable Switch Terminal	Compatible with the cable switch CS-205 (optional) (Ø2.5 mm)
-----------------------	--

Dimensions and Weight

Dimensions	Approx. 127.0 mm (W) × 78.0 mm (H) × 52.0 mm (D) (5.0 in. (W) × 3.1 in. (H) × 2.0 in. (D)) (excluding protruding parts)
Weight	Approx. 290 g (10.2 oz) (without film and battery)

Operating Environment

Temperature	0 to 40°C (32 to 104°F)
Humidity	85% or less (the environment must be free of condensation)

Included Accessories

Included Items	Lens cap O-LC40.5, Strap O-ST191
----------------	----------------------------------

Handling Precautions

Before Using Your Camera

- When the camera has not been used for a long time, confirm that it is still working properly, particularly prior to taking important photos (such as at a wedding or when traveling). Contents of taken photos cannot be guaranteed if photo development, etc. is not possible due to a malfunction of your camera.

Precautions on Carrying and Using Your Camera

- Do not subject the camera to high temperatures or high humidity. Do not leave the camera in a vehicle, as the temperature can get very high.
- Do not subject the camera to strong vibrations, shocks, or pressure. Use a cushion to protect the camera from vibrations of motorcycles, automobiles, or ships.
- Sudden temperature changes will cause condensation on the inside and outside of the camera. Place the camera in your bag or a plastic bag, and remove it after temperatures of the camera and surroundings are equalized.
- Avoid contact with garbage, mud, sand, dust, water, toxic gases, or salt. These could cause the camera to breakdown. Wipe the camera to dry off any rain or water drops.
- The camera is not water resistant, so it cannot be used in places where it will get wet, such as in the rain.
- Do not leave the camera for long periods of time in direct sunlight with film left inside. Doing so may expose the film.
- Be careful not to overtighten the screw in the tripod socket when using a tripod.

Cleaning Your Camera

- Do not clean the camera with organic solvents such as thinner, alcohol, and benzine.
- Use a lens brush to remove dust accumulated on a lens. Never use a spray blower for cleaning as it may damage the lens.
- Periodic inspections are recommended every one to two years to maintain high performance.

Storing Your Camera

- Do not store the camera with preservatives or chemicals. Storage in high temperatures and high humidity can cause mold to grow on the camera. Store it in a dry and well-ventilated place.
- Avoid using or storing the camera where it may be exposed to static electricity or electrical interference.
- Avoid using or storing the camera in direct sunlight or in locations where it may be exposed to rapid changes in temperature or to condensation.

Warranty Policy

All our cameras purchased through authorized bona fide photographic distribution channels are guaranteed against defects of material or workmanship for a period of twelve months from the date of your purchase. Service will be rendered, and defective parts will be replaced without cost to you within that period, provided the camera does not show evidence of impact, sand or liquid damage, mishandling, tampering, battery or chemical corrosion, operation contrary to operating instructions, or modification by an unauthorized repair shop. The manufacturer or its authorized representatives shall not be liable for any repair or alterations except those made with its written consent and shall not be liable for damages from delay or loss of use or from other indirect or consequential damages of any kind, whether caused by defective material or workmanship or otherwise; and it is expressly agreed that the liability of the manufacturer or its representatives under all guarantees or warranties, whether expressed or implied, is strictly limited to the replacement of parts as hereinbefore provided. No refunds will be made on repairs by non-authorized service facilities.

4

Appendix

Procedure During 12-month Warranty Period

Any camera which proves defective during the 12-month warranty period should be returned to the dealer from whom you purchased the camera or to the manufacturer. If there are no representatives of the manufacturer in your country, send the camera to the manufacturer, with postage prepaid. In this case, it will take a considerable length of time before the camera can be returned to you owing to the complicated customs procedures required. If the camera is covered by warranty, repairs will be made and parts replaced free of charge, and the camera will be returned to you upon completion of servicing. If the camera is not covered by warranty, regular charges of the manufacturer or of its representatives will apply. Shipping charges are to be borne by the owner. If your camera was purchased outside of the country where you wish to have it serviced during the warranty period, regular handling and servicing fees may be charged by the manufacturer's representatives in that country. Notwithstanding this, your camera returned to the manufacturer will be serviced free of charge according to this procedure and warranty policy. In any case, however, shipping charges and customs clearance fees to be borne by the sender. To prove the date of your purchase when required, please keep the receipt or bills covering the purchase of your camera for at least a year. Before sending your camera for servicing, please make sure that you are sending it to the manufacturer's authorized representatives or their approved repair shops, unless you are sending it directly to the manufacturer. Always obtain a quotation for the service charge, and only after you accept the quoted service charge, instruct the service station to proceed with the servicing.

- **This warranty policy does not affect the customer's statutory rights.**
- **The local warranty policies available from our distributors in some countries can supersede this warranty policy. Therefore, we recommend that you review the warranty card supplied with your product at the time of purchase, or contact our distributor in your country for more information and to receive a copy of the warranty policy.**

For Customers in USA and Canada

Conditions of RICOH IMAGING North America Warranty

1. RICOH IMAGING products originally distributed by RICOH IMAGING AMERICAS CORPORATION and RICOH IMAGING CANADA and purchased through our authorized distribution channels, are warranted by RICOH IMAGING AMERICAS CORPORATION and RICOH IMAGING CANADA to the original retail purchaser for a period of one year from date of purchase against defects in material and/or workmanship.
2. This warranty is limited to repair of defects in material and/or workmanship. These repairs will be made at no charge to the customer. However, all charges related to shipping the product to the service center are the responsibility of the owner. (Note: RICOH IMAGING AMERICAS CORPORATION and RICOH IMAGING CANADA will not assume the responsibility for damages or loss encountered in transit to the service center but will assist in processing any claims whenever possible.)
3. This warranty does not cover finishes or batteries, nor does it cover damages resulting from accident, misuse, abuse, dirt, water, sand, battery leakage, tampering, servicing performed or attempted by unauthorized service agencies. This warranty is valid only in the country where this product is purchased. Routine cleaning and normal cosmetic and mechanical wear are not covered under the terms of this warranty. RICOH IMAGING AMERICAS CORPORATION and RICOH IMAGING CANADA shall not be liable for any consequential or incidental damages resulting from any breach of warranty, express or implied, applicable to this product.
4. Please be sure to keep your original or a copy of your proof of purchase receipt (bill of sale), to obtain warranty service during the warranty period. The dated proof of purchase receipt (bill of sale) must be provided to ensure warranty status. If the dated proof of purchase receipt (bill of sale) is not received with the product, a repair estimate will be issued.

Some states do not allow limitations on how long an implied warranty lasts, so the above limitations may not apply to you. Some states do not allow the exclusion or limitation of incidental or consequential damages, so the above limitations may not apply to you. This warranty gives you specific rights and you may have other legal rights which vary from state to state. This warranty policy does not affect the consumer's statutory rights.

Register your product:

USA: <https://us.ricoh-imaging.com/register-product/>

CAN: <https://www.ricoh-imaging.ca/register-your-ricoh-imaging-product/>

For service-related inquiries:

USA: <https://us.ricoh-imaging.com/repairs/>

CAN: <https://www.ricoh-imaging.ca/support/repairs/>

For technical support:

USA: <https://us.ricoh-imaging.com/online-support/>

Tel: 1-800-234-0276

CAN: <https://www.ricoh-imaging.ca/support/digital-support/>

Tel: 1-800-224-6767

Pour les utilisateurs aux États-Unis et au Canada

Conditions de garantie RICOH IMAGING en Amérique du Nord

1. Les produits RICOH IMAGING distribués à l'origine par RICOH IMAGING AMERICAS CORPORATION et RICOH IMAGING CANADA et achetés par l'entremise de nos réseaux de distribution dûment agréés sont garantis par RICOH IMAGING AMERICAS CORPORATION et RICOH IMAGING CANADA contre tout défaut de fabrication et de main-d'œuvre pendant un an à partir de la date d'achat initiale pour l'acheteur original.
2. Cette garantie se limite aux réparations des défauts de fabrication et de main-d'œuvre. Ces réparations seront effectuées sans frais pour le client. Cependant, tous les frais reliés à l'envoi du produit dans un Centre de service seront à la charge de l'utilisateur. (Nota : RICOH IMAGING AMERICAS CORPORATION et RICOH IMAGING CANADA n'assumeront aucune responsabilité pour les dommages ou perte pouvant survenir lors du transport, mais assistera dans le traitement de toute réclamation dans la mesure du possible.)
3. Cette garantie ne couvre pas le fini ni les piles, et ne couvre pas non plus les dommages résultant d'un accident, d'une utilisation inappropriée ou abusive ainsi que de la poussière, eau, écoulement des piles, modifications ou réparations réalisées ou tentées par une agence de réparation non agréée. Cette garantie n'est valable que dans le pays où le produit a été acheté. Le nettoyage de routine et l'usure mécanique et esthétique ne sont pas couverts par cette garantie. RICOH IMAGING AMERICAS CORPORATION et RICOH IMAGING CANADA ne peuvent être tenues responsables des dommages accidentels, indirects et consécutifs résultant d'un manquement à une condition de la garantie, expresse ou implicite, applicable à ce produit.
4. Conservez votre bon d'achat original (facture de vente datée) ou une copie afin de fournir lors d'une demande de réparation pendant la période de garantie. Votre bon d'achat doit être fournie pour assurer l'état de la garantie. Si votre bon d'achat n'est pas reçue avec le produit, un devis de réparation sera émis.

Certains pays, états ne permettent pas de limiter la durée d'une garantie implicite, donc les limitations citées ci-dessus peuvent ne pas s'appliquer à vous. De même, certains pays, états permettent pas l'exclusion ou la limitation des dommages accidentels ou consécutifs, en conséquence, les limitations peuvent ne pas s'appliquer à vous. Cette garantie vous donne des droits spécifiques et vous pouvez avoir d'autres droits selon la juridiction en vigueur dans votre région. Cette garantie ne peut diminuer les droits juridiques du consommateur.

Renseignement relatif au service :

<https://www.ricoh-imaging.ca/fr/service-et-solution/repairs/>

Soutien technique :

<https://www.ricoh-imaging.ca/fr/service-et-solution/soutien-technique/>

For Customers in USA

STATEMENT OF FCC COMPLIANCE

Supplier's Declaration of Conformity 47 CFR § 2.1077 Compliance Information

Product Name: PENTAX 17

Model Number: R08010

This device complies with Part 15 of the FCC Rules. Operation is subject to the following two conditions: (1) This device may not cause harmful interference, and (2) this device must accept any interference received, including interference that may cause undesired operation.

Responsible party: RICOH IMAGING AMERICAS CORPORATION

Address: 2 Gatehall Drive Suite 204, Parsippany, New Jersey 07054, U.S.A.

Phone: 800-877-0155

Changes or modifications not expressly approved by the party responsible for compliance could void the user's authority to operate the equipment.

FCC Part 15 Subpart B Class B

This equipment has been tested and found to comply with the limits for a Class B digital device, pursuant to part 15 of the FCC Rules. These limits are designed to provide reasonable protection against harmful interference in a residential installation. This equipment generates, uses and can radiate radio frequency energy and, if not installed and used in accordance with the instructions, may cause harmful interference to radio communications. However, there is no guarantee that interference will not occur in a particular installation. If this equipment does cause harmful interference to radio or television reception, which can be determined by turning the equipment off and on, the user is encouraged to try to correct the interference by one or more of the following measures:

- Reorient or relocate the receiving antenna.
- Increase the separation between the equipment and receiver.
- Connect the equipment into an outlet on a circuit different from that to which the receiver is connected.
- Consult the dealer or an experienced radio/TV technician for help.

For Customers in Canada
Innovation, Science and Economic Development Canada (ISED)
Regulatory Compliance Notice

This Class B digital apparatus complies with Canadian ICES-003 (B).

Pour les utilisateurs au Canada
Avis de conformité à la réglementation d'Innovation, Sciences et
Développement économique Canada (ISDE)

Cet appareil numérique de la classe B est conforme à la norme NMB-003 (B) du Canada.

For Customers in Europe

Information for Users on Collection and Disposal of Old Equipment and Used Batteries



1. In the European Union

This symbol on the products, packaging and/or accompanying documents means that used electrical and electronic equipment and batteries should not be mixed with general household waste.

Used electrical/electronic equipment and batteries must be treated separately and in accordance with legislation that requires proper treatment, recovery and recycling of these products.

By disposing of these products correctly you will help ensure that the waste undergoes the necessary treatment, recovery and recycling and thus prevent potential negative effects on the environment and human health which could otherwise arise due to inappropriate waste handling.

2. In other countries outside the EU

This symbol is only valid in the European Union. If you wish to discard used products, please contact your local authorities or dealer and ask for the correct method of disposal.

For Switzerland: Used electrical/electronic equipment can be returned free of charge to the dealer, even when you don't purchase a new product. Further collection facilities are listed on the home page of www.swico.ch or www.sens.ch.

Notice to Users in Countries that Require the CE Marking

This product complies with the essential requirements and provisions of EMC Directive 2014/30/EU.

Importer (CE Marking): RICOH IMAGING EUROPE S.A.S.
7-9, avenue Robert Schuman, 94150 Rungis, FRANCE

Manufacturer: RICOH IMAGING COMPANY, LTD.
1-3-6, Nakamagome, Ohta-ku, Tokyo 143-8555, JAPAN



The CE Mark is a Directive conformity mark of the European Union.

Notice to Users in Countries that Require the UKCA Marking

This product complies with the essential requirements and provisions of Electromagnetic Compatibility Regulations 2016.

Manufacturer : RICOH IMAGING COMPANY, LTD.
1-3-6, Nakamagome, Ohta-ku, Tokyo 143-8555, JAPAN



The UKCA Mark is a Regulation conformity mark of the United Kingdom.

Index

A

Advance 17

B

Battery 13

Bulb shooting 26

C

Close distance 27

Close-up 27

Close-up visual field compensation
frame 11

D

Daylight sync shooting 24

E

Exposure compensation 29

Extremely close distance 27

F

Far distance 27

Film 14

Film sensitivity 15

Filter 30

Flash 24

Focus 27

Full auto shooting 22

H

Half-frame 14

Holding the camera 21

I

Indicator lamp 10

ISO sensitivity dial 15

L

Long exposure 26

M

Macro 27

Maximum aperture priority
shooting 23

Medium distance 27

Mode dial 23

N

Names of the working parts 6

Note holder 19

P

Package contents 5

Power 14

R

Rewind 20

S

Shooting mode 23

Shooting range 27

Slow-speed shutter shooting 23

Slow-speed sync shooting 24

Specifications 33

Standard shooting 23

Strap 12

T

Tabletop photo 27

V

Viewfinder display 11

Visual field frame 11

W

Warranty policy 38

Z

Zone focusing mark 11

Zone focusing ring 27

RICOH

RICOH IMAGING COMPANY, LTD.

1-3-6, Nakamagome, Ohta-ku, Tokyo 143-8555,
JAPAN
(<https://www.ricoh-imaging.co.jp>)

RICOH IMAGING EUROPE S.A.S.

7-9, avenue Robert Schuman, 94150 Rungis,
FRANCE
(<https://www.ricoh-imaging.eu>)

RICOH IMAGING AMERICAS CORPORATION

2 Gatehall Drive Suite 204, Parsippany, New Jersey
07054, U.S.A.
(<https://www.us.ricoh-imaging.com>)

RICOH IMAGING CANADA INC.

5560 Explorer Drive Suite 100, Mississauga, Ontario,
L4W 5M3, CANADA
(<https://www.ricoh-imaging.ca>)

RICOH IMAGING CHINA CO., LTD.

Room A 23F Lansheng Building, 2-8 Huaihaizhong
Road, Huangpu District, Shanghai, 200021, CHINA
(<https://www.ricoh-imaging.com.cn/china/>)

<https://www.ricoh-imaging.co.jp/english/>

This contact information may change without
notice. Please check the latest information on our
websites.